

MANUAL

Installation / Operation / Maintenance

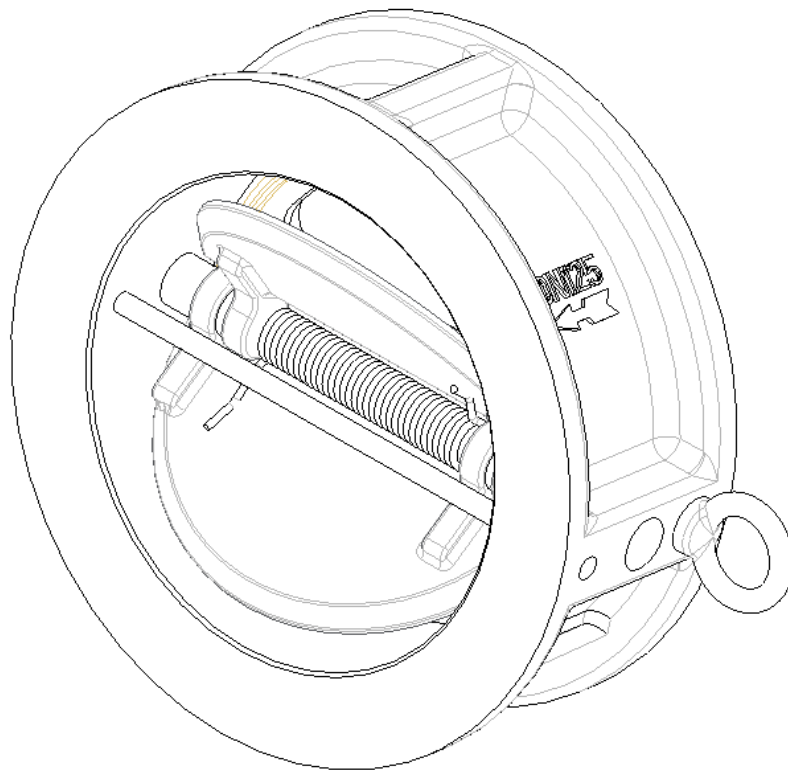

Flange STD: ANSI 150 (PN16/20)
ANSI 300 (PN40/50)
ANSI 600 (PN100)
Temp : -10 ~ +120 Deg C
Working pressure: 20~50~100 BAR
Date: 2002



Please read all of these instructions before
Installing your CV-123 valve

MADE IN TAIWAN



Flow Control Company Ltd

Cooper Drive,
Springwood Industrial Estate,
Braintree, Essex CM7 2RF
Tel: +44 (0) 1376 321211 **Fax:** +44 (0) 1376 321222
E-mail: sales@flowcontrol.co.uk
Web site: www.flowcontrol.co.uk

Operating Manual	Issue Date	May.23, 2002	Edition	1
Installation: Operation & Maintenance Instructions			Number	CV-123-O

Flange STD :ANSI 150, 300, 600 # ~ PN16/40
Temp : -10 ~ +220 Deg C
Rating : **CV-123A 150lb (PN16/20)**
CV-123B 300lb (PN40/50)
CV-123C 600lb (PN100)

Installation, Removal and Maintenance:

The valve must be installed so that pipeline stresses are not transmitted to the valve body. Despite its solid manufacture, such stress may affect valve operation.

1. Installation:

1. All valves must be in a fully closed position during installation or removal. It is not necessary to torque seat the valve, but the disc travel must be restricted to prevent damage.
2. Please be sure that the valve is clean and that there is no Foreign material inside the pipework and valve.
3. The shaft part of the disc is considered the high-pressure side of the valve, (as indicated on the drawings by a flow arrow). Therefore the effective closure performance is obtained on this side of the valve, and a determination as to the best installation should be made, to utilize this feature. Make sure that the valve is installed using the flow direction arrow as shown on (Fig1).
4. Please install the valve stem vertically as (Fig.2), this reduces spring wear.
5. Install valve and gaskets into pipeline as (Fig.3).
6. Make sure the valve is installed concentrically between the flanges, this lowers the current velocity loss.
7. Use a pipe spool piece between wafer check valve and butterfly valve, never connect them directly. (Fig.4)

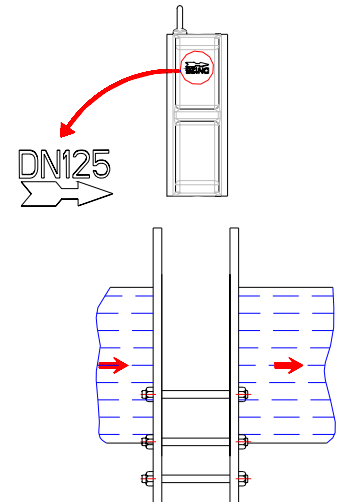

Fig. 1

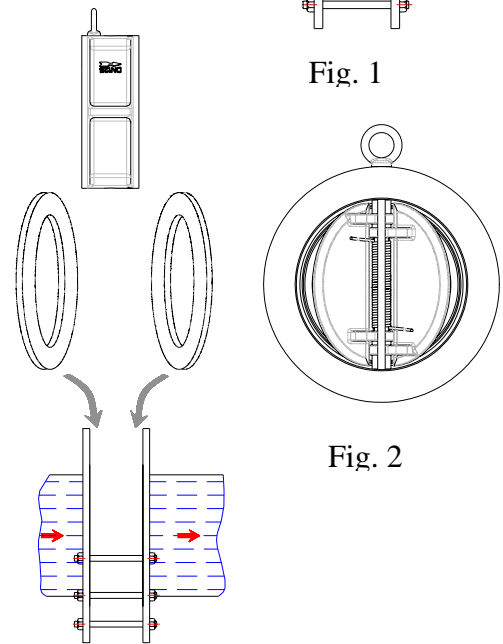

Fig. 2

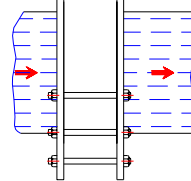

Fig 3.

2. Flange Connecting and Bolting :

1. Keep valve flange protectors on until installation.
2. Make sure the material and size of gaskets is suitable for the service conditions, check that the faces of the flanges and valve are smooth and flat.
3. Check that all the nuts and bolts are in good condition.
4. Apply lubricant such as Molybdenum to all the bolts and nuts before fixing them.
5. The optimum spacing would be such as to only allow the flange gasket to be installed, at the maximum, and the flange bolt holes should be concentric.
6. Complete the tightening of all flanges bolting in a minimum of four increments to the final determined torque value. (Table 1).
7. Actual torque shall depend on gasket type, consult gasket manufacturer.
8. Bolt tightening sequence and torques (Table 1)

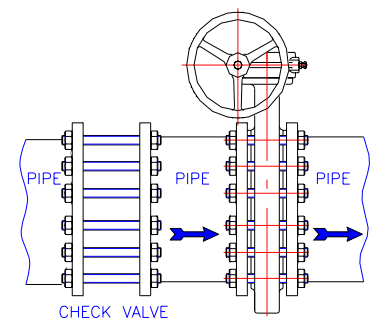

Fig.4

Operating Manual	Issue Date	May.23, 2002	Edition	1
Installation : Operation & Maintenance Instructions			Number	CV-123-O

3. Removal Procedure:

To remove your valve from the pipeline, please follow these simple steps:

1. Ensure the valve is in the closed position.
2. Ensure the line is depressurized.
3. Use protective clothing and equipment to prevent injury.
4. Attach nylon slings to the body shoulders of the valve and around the body of the actuator.
5. Remove the bolts holding the valve to the pipeline flanges.
6. Remove the valve.

Bolt size	Torque	
	ft-lb	Nm
5/8" (M16)	110	150
3/4" (M20)	200	270
7/8" (M22)	320	434
1" (M26)	480	650
1-1/8"(M28)	600	815
1-1/4"(M32)	840	1140

Table 1

4. Maintenance:

We recommend that the valve be checked every 3 months to determine if the valve needs to be maintained or lubricated.

5. Casting Mark

1. 16 : The Imperial System Diameter.(Fig. 5)
2. 150 : Pressure Rating. (Fig. 5)
3. WCB : Material. (Fig. 6)
4. Arrow : Recommended Flow Direction. (Fig. 6)

16-150

Fig. 5



Fig. 6

6. Nameplate (Fig. 7)

1. CE: CE MARK.
2. V: VALUE Mark.
3. SERIES NO. : Product Number.
4. BATCH NO. : 91365
91 :Year.
365 : Series Number.
5. MWP : Max. Working Pressure.
6. TEMP : Operating Temperature.
7. BODY ~ DISC ~STEM ~ SEAT : Material of the parts.

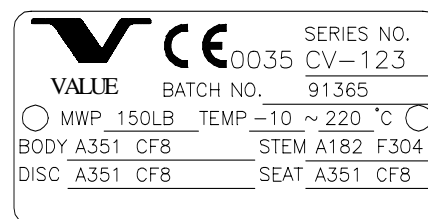

Fig. 7

7. Trouble shooting

You may try the following procedures before contacting VALUE VALVES or FLOW CONTROL.

If your valve doesn't operate properly before or after trying these trouble-shooting ideas, please contact FLOW CONTROL at +44 01376 321211 for assistance.

Disc has been pitted.

If the phenomenon is discovered, first clean the fluid in the pipe and valve. Inspect the stem and spring. If it has corroded or eroded, please contact the nearest Flow Control or Value's agency to service.

8. Maintenance

1. The valve is not suitable for a flow containing foreign material such as metal fillings etc, which could damage the valve seats.
2. Make sure that the valve is suitable for the flange connection, pressure and temperature.
3. Operating temperature should not be higher or lower than stated sign on the nameplate. If you have special requirement please contract Flow Control for further information.
4. Maximum working pressure must not be higher than its design pressure.
5. Make sure that the fluid is not corrosive.