



BAC VALVES

BARE STEM DIMENSIONS
DIMENSIONES SALIDAS DE EJES
TIPO / TYPE NP "Guiada / Trunnion"

HT-BV12E

Plano N° 02-4007 Rev. C

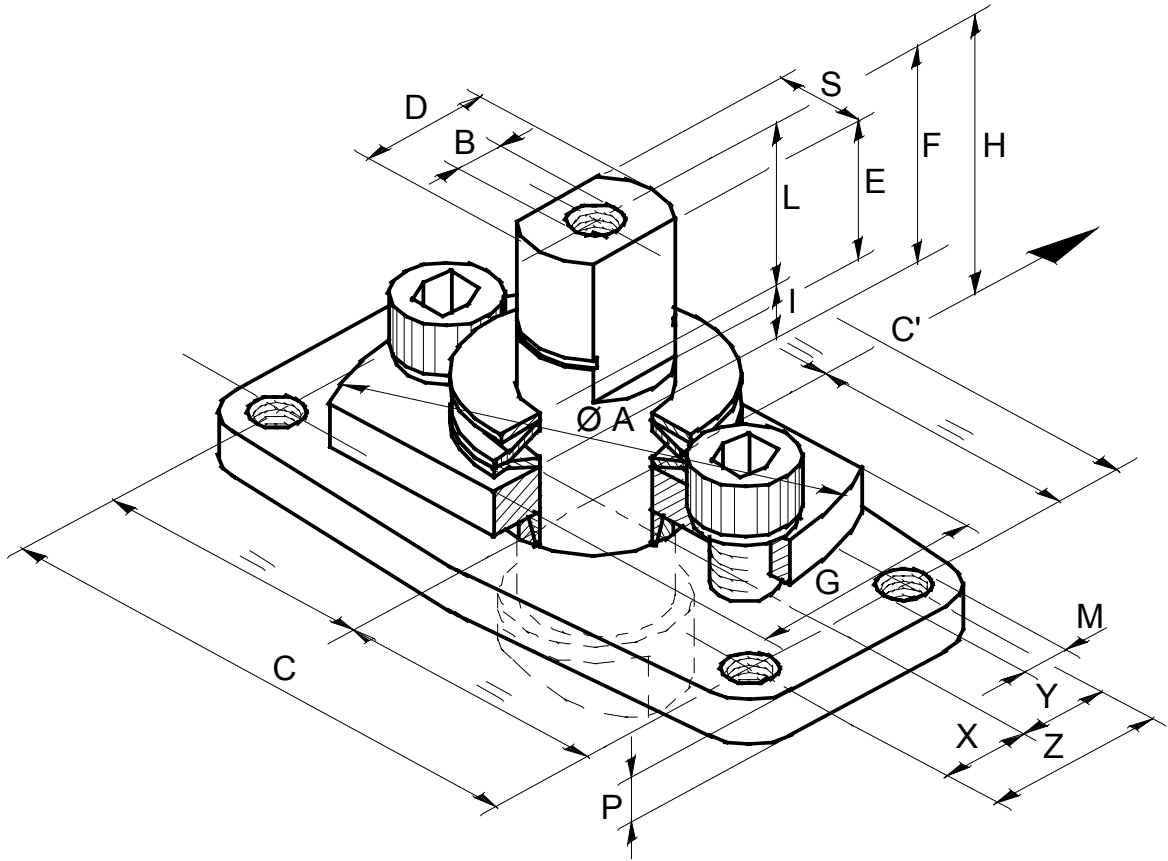

NPS	DN	D	B	F	E	S	C	C'	X	Y	Z	M	P	I	H	L	*	A	G
10"	250	45	M 12	48.5	44	30	190	190	40	40	80	M 16	20	12	69	36.5	1.5	146	90
12"	300	60	M 12	59	55	40	194	194	38	38	76	M 20	25	12	84.5	47	2	156	100
14"	350	70	M 12	59	55	45	194	194	38	38	76	M 20	26	12	84	47	2	156	120
16"	400	80	M 12	45.5	40	50	230	230	49	49	98	M 20	30	12	83.5	33.5	2	180	140

For the assembly (mounting) of actuators, the L dimensions must be increased according to (*)

Para el montaje de actuadores, la dimensión L tiene que incrementarse de acuerdo con (*)

L = without compression / sin compresión

* = compression / compresión