

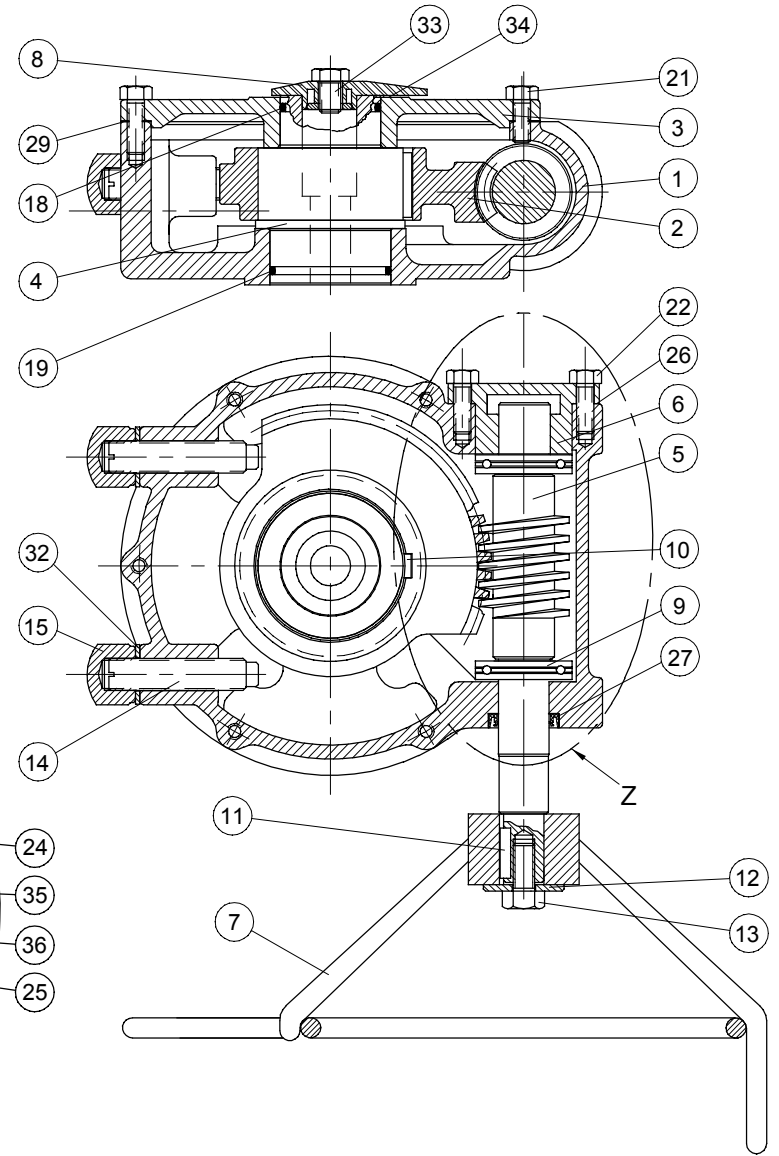

TIPO	RK-45	RK-75	RK-125
PAR MAX Nm	450	1000	2500
REDUCCIÓN	1 / 50	1 / 52	1 / 50
VUeltas 90°	12.5	13	12.5
RENDIMIENTO	33%	33%	35%
PAR MAX VOL. Nm	30	62	150
PESO Kg.	10	23	47
A	81	122	187
B	96	135	200
C	65	98	152
D	345	370	540
F	105	120	150
G	75	92	156
J	270	294	462
N	37	43	62
ISO 5211	F10	F12	F14

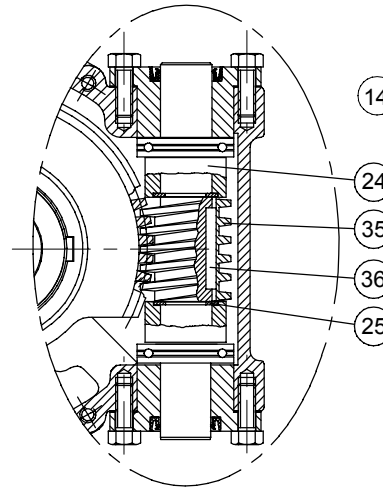

DETALLE Z
DETAIL Z
PARA RK-125
FOR RK-125



POS.	DESCRIPTION	QTY.	MATERIAL	EQUIVALENT STANDARD			FINISH
				BS	AISI-ASTM	ISO-DIN	
1	CUERPO / BODY	1	NODULAR CAST	SNG-37/7	GR/40.18	0.7040	EPOXI COATED
2	CORONA / QUADRANT	1	IRON CAST	GR-17	A126 Cl.B	0.6025	
3	TAPA / END-CAP	1	NODULAR CAST	SNG-37/7	GR60/40.18	0.7040	EPOXI COATED
4	EJE / MAIN SHAFT	1	CARBON STEEL	060 A 47	G10450	10.503	
5	EJE SIN FIN / WORM GEAR	1	CARBON STEEL	060 A 47	G10450	10.503	
6	TAPETA / END-CAP	1	IRON CAST	GR-17	A126 Cl.B	0.6025	EPOXI COATED
7	VOLANTE / HANDWHEEL	1	CARBON STEEL	060 A 47	G10450	1.0503	
8	INDICADOR / INDICATOR	1	NYLON+30% LOAD				
9	RODAMIENTO / BEARING	2	CARBON STEEL				
10	CHAVETA CORONA / KEY	1	CARBON STEEL	653 M 31	A325	8.8	
11	CHAVETA VOLANTE / KEY	1	CARBON STEEL	653 M 31	A325	8.8	
12	ARANDELA VOLANTE / WASHER	1	CARBON STEEL	653 M 31	A325	8.8	ZINC PLATED
13	TORNILLO / BOLT DIN-933	1	CARBON STEEL	653 M 31	A325	8.8	ZINC PLATED
14	ESPARRAGO / STUD	2	CARBON STEEL	653 M 31	A325	8.8	
15	TUERCA TOPE / LUCK NUT	2	CARBON STEEL	653 M 31	A325	8.8	EPOXI COATED
18	O-RING	1	BUNA-N				
19	O-RING	1	BUNA-N				
21	TORNILLO / BOLT DIN-912	6	CARBON STEEL	653 M 31	A325	8.8	EPOXI COATED
22	TORNILLO / BOLT DIN-933	4	CARBON STEEL	653 M 31	A325	8.8	EPOXI COATED
24	CASQUILLO / BUSH	2	CARBON STEEL	060 A 47	G10450	1.0503	
25	ANILLO / RING		CARBON STEEL	653 M 31	A325	8.8	
26	JUNTA / SEAL	1	VELLOMOID	SPECIAL PAPER (OIL DIPPED)			
27	RETEN / RETAINER	1	BUNA-N				
29	JUNTA / SEAL	1	VELLOMOID	SPECIAL PAPER (OIL DIPPED)			
32	ARANDELA / WASHER	2	ALUMINIUM				
33	TORNILLO / BOLT	1	CARBON STEEL	653 M 31	A325	8.8	
34	ARANDELA / WASHER	1	CARBON STEEL	653 M 31	A325	8.8	
35	SIN FIN / WORM GEAR	1	CARBON STEEL	060 A 47	G10450	10.503	
36	CHAVETA SIN FIN / WORM GEAR	1	CARBON STEEL	653 M 31	A325	8.8	



Tapis, 126 - P.O. Box, 13 - 17600 FIGUERES (Girona) Spain
Tel.: (34) 972 67 70 52 - **Fax:** (34) 972 50 90 40
E-mail: technical@bacvalves.com **web:** www.bacvalves.com

TITULO / TITLE REDUCTORES GEARBOXES TIPO / TYPE RK-45, RK-75, RK-125		Dibujado / Drawn Enric Balsera Aprobado / Approved Carles Bach Plano nº / Drawing nr. 07-2806	Escala / Scale Fecha / Date 08-02-99 Rev. B
---	--	---	--

Prohibido el uso y reproducción de este plano parcial o totalmente, sin expresa autorización de BAC VALVES S.A.
 Any partially or totally use or reproduction of this drawing, without specific authorization of BAC VALVES S.A. is forbidden.